

Hard conversion jaws serration/tongue & groove ground

- To mount top jaws to chucks with different master jaw dimensions
- Simply copy and fax to: +49 (0) 7542 3886
- Download from www.smw-autoblok.de

Conversion jaw type AD 10

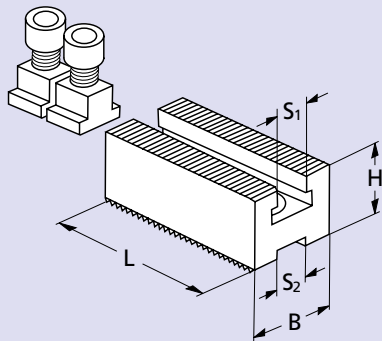

Dimensions

Serration chuck side (please mark)

	1/16" x 90°		1.5 x 60°
	3/32" x 90°		3 x 60°

S2	mm		
----	----	--	--

Serration jaw side (please mark)

	1/16" x 90°		1.5 x 60°
	3/32" x 90°		3 x 60°

S1	mm	B	mm
H	mm	L	mm

Chuck manufacturer

Chuck type + Size

Fine serration on both sides.

T-nuts and bolts are special according to the existing top jaws.

Conversion jaw type AD 50

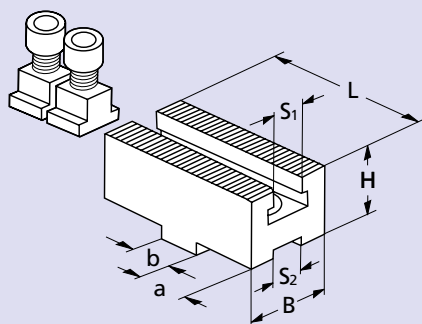

Dimensions

Serration jaw side (please mark)

	1/16" x 90°		1.5 x 60°
	3/32" x 90°		3 x 60°

S1	mm	B	mm
----	----	---	----

H	mm	L	mm
---	----	---	----

a	mm	b	mm
---	----	---	----

S2	mm		
----	----	--	--

Chuck manufacturer

Chuck type + Size

Tongue and groove on the chuck and fine serration on the jaws.

T-nuts and bolts are special according to the existing top jaws.

Conversion jaw type AD 30

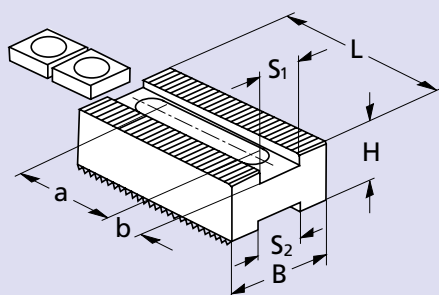

Dimensions

Serration chuck side (please mark)

	1/16" x 90°		1.5 x 60°
	3/32" x 90°		3 x 60°

S2	mm		
----	----	--	--

Serration jaw side (please mark)

	1/16" x 90°		1.5 x 60°
	3/32" x 90°		3 x 60°

S1	mm	B	mm
----	----	---	----

H	mm	L	mm
---	----	---	----

a	mm	b	mm
---	----	---	----

Chuck manufacturer

Chuck type + Size

Fine serration on both sides.

The conversion jaw has a slot so that it can match different bolts patterns.

Conversion jaw type AD 80

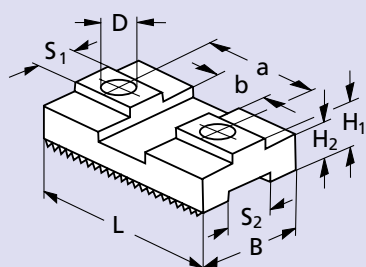

Dimensions

Serration chuck side (please mark)

	1/16" x 90°		1.5 x 60°
	3/32" x 90°		3 x 60°

S1	mm	B	mm
----	----	---	----

H1	mm	L	mm
----	----	---	----

H2	mm	a	mm
----	----	---	----

S2	mm	b	mm
----	----	---	----

Chuck manufacturer

Chuck type + Size

Tongue and groove on the jaw and fine serration the chuck.

The size and position of the holed D are depending on the existing T-nuts.