

Hard special jaws to customer request

- Simply copy and fax to: +49 (0) 7542 3886
- Download from www.smw-autoblok.de

Hard top jaws for external clamping with smooth clamping surface

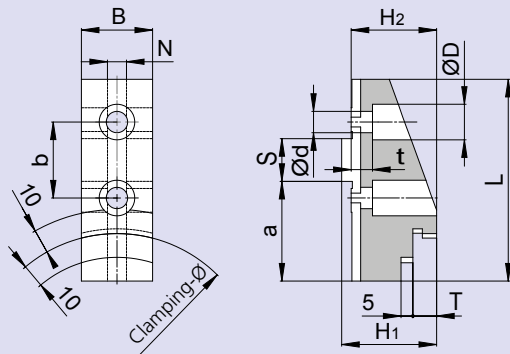

Dimensions					
a		mm	L		mm
b		mm	N		mm
B		mm	S		mm
d		mm	t		mm
D		mm	T		mm
H1		mm	Clamping-Ø		mm
H2		mm	Workpiece-Ø		mm

Material
Quantity in pieces
Chuck manufacturer
Chuck type + size

Hard top jaws for internal clamping with smooth clamping surface

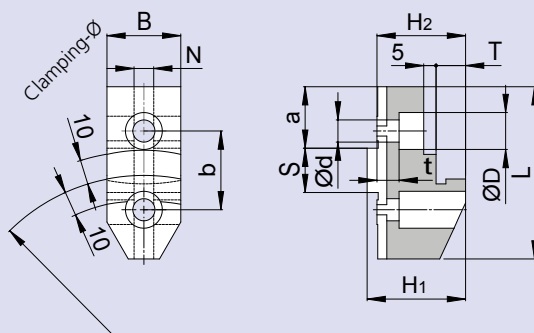

Dimensions					
a		mm	L		mm
b		mm	N		mm
B		mm	S		mm
d		mm	t		mm
D		mm	T		mm
H1		mm	Clamping-Ø		mm
H2		mm	Workpiece-Ø		mm

Material
Quantity in pieces
Chuck manufacturer
Chuck type + size

Hard top jaws for external clamping with serrated clamping surface

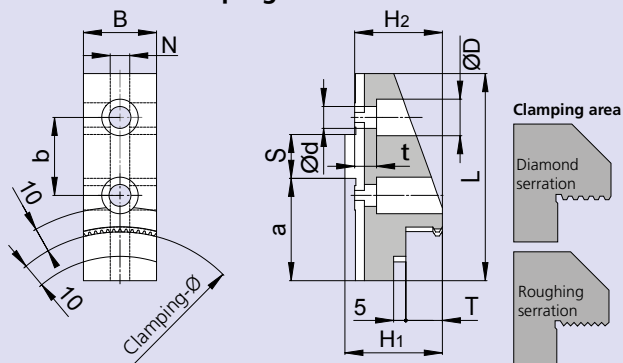

Dimensions					
a		mm	L		mm
b		mm	N		mm
B		mm	S		mm
d		mm	t		mm
D		mm	T		mm
H1		mm	Clamping-Ø		mm
H2		mm	Workpiece-Ø		mm

Clamping area (please mark)

Diamond serration
 Roughing serration

Material
Quantity in pieces
Futterhersteller
Chuck type + size

Hard top jaws for internal clamping with serrated clamping surface

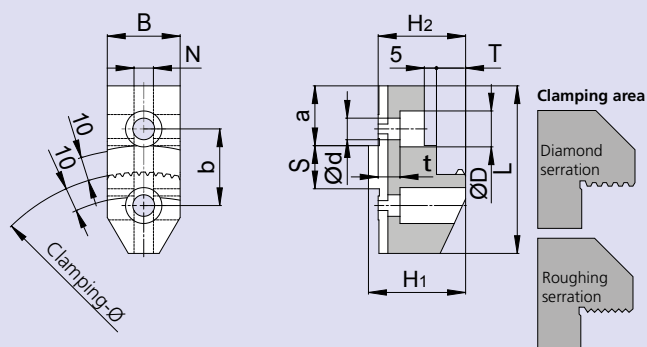

Dimensions					
a		mm	L		mm
b		mm	N		mm
B		mm	S		mm
d		mm	t		mm
D		mm	T		mm
H1		mm	Clamping-Ø		mm
H2		mm	Workpiece-Ø		mm

Clamping area (please mark)

Diamond serration
 Roughing serration

Material
Quantity in pieces
Chuck manufacturer
Chuck type + size