

Stop pins ALB

SMW-AUTOBLOK Type	Id. No.	G	H	SW
ALB 505	016510	M5	5	10
ALB 510	016508	M5	10	10
ALB 515	016509	M5	15	10
ALB 605	016513	M6	5	10
ALB 610	016511	M6	10	10
ALB 615	016512	M6	15	10
ALB 620	017602	M6	20	10
ALB 805	017603	M8	5	13
ALB 810	016514	M8	10	13
ALB 815	016515	M8	15	13
ALB 820	016516	M8	20	13
ALB 825	081191	M8	25	13

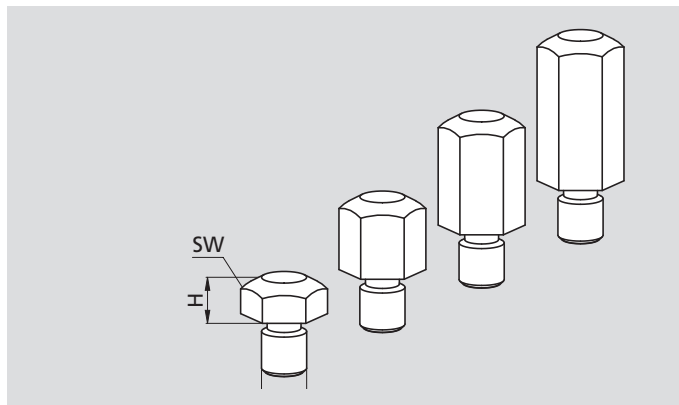

Jaw mounting bolts for base jaws type GBK, GBK-2G, GBKS, GBK-B, GBK-B-2G, MFG

■ Screw ISO 4762, Class 12.9

GM

GF

Jaw mounting bolts

Type	Id. No.	G x Length	SMW-AUTOBLOK Base jaws
GM 820	010182	M8 x 20	GBK 140 GBK 160 GBK 200 GBK-2G 170 GBK-2G 200 GBKS 200 GBKB 210
GM 1225	015524	M12 x 25	GBK 250 GBK 260 GBK 315 GBK-2G 250 GBK-2G 315 GBKS 250 GBKS 315 GBKB 315
GM 1230	010207	M12 x 30	GBK 400 GBK-2G 400 GBKS 400 GBKB 400
GM 1645	010448	M16 x 45	GBK 500 GBK 630 GBK-2G 500 GBK-2G 630 GBKB 500 GBKB 630 GBKB 800 GBK-B-2G 630 GBK-B-2G 800
GM 2045	082498	M20 x 45	MFG 630
GF 820	084331	M8 x 1 x 20	MFG 160 MFG 200
GF 1230	087603	M12 x 1.5 x 30	MFG 250
GF 1235	087733	M12 x 1.5 x 35	MFG 315
GF 1640	086405	M16 x 1.5 x 40	MFG 400

