

TSX-C 2+2

Pull down chuck
4 jaws 2+2

High precision pull-down chuck Ø 265 - 315 mm

- Active pull-down
- 2+2 jaws
- Tongue & groove

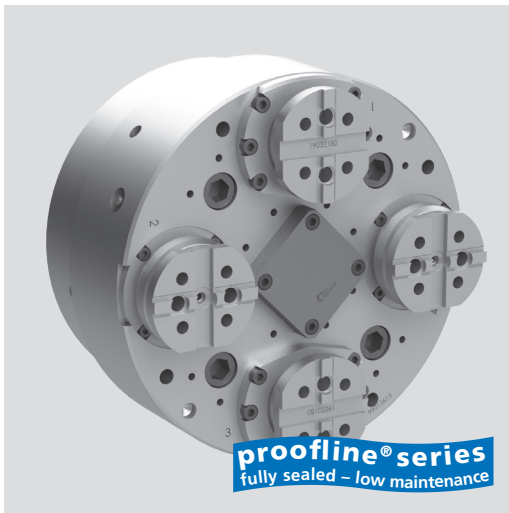

Application/customer benefits

- Self-centering clamping of irregular pieces on four sides even on two different axial levels. For example: 1st operation of the differential case turning
- Machining of parts where the concentricity between the turned diameters and the square / rectangular / irregular profile on which the chuck clamps is very accurate
- Centering the pieces with the two self-centering movements of the two pairs of jaws
- Actuation only with double piston cylinders of the series DCE
- Clamping of workpieces with highest demand for **parallelism**
- **Highest productivity** with long maintenance intervals
- Constant grip force and long lifetime ensure **constant quality of workpieces**

Technical features

- 2+2 jaw chuck with 2 independent self-centering jaw drives, thanks to the 2 internal wedges
- Jaw 1 + 3: TX jaws very rigid and accurate
- Jaw 2 + 4: Can be rigid (TSXR-C) or floating depending on the customer application
- Active pull-down
- Centrifugal force compensation
- TONGUE & GROOVE master jaws
- Optional central hole for air or coolant
- Permanent grease lubrication
- **proofline® chucks** = fully sealed - low maintenance

Standard equipment

2+2 jaw chuck
Mounting bolts

Ordering example

2+2 jaw chuck TSXR-C 265

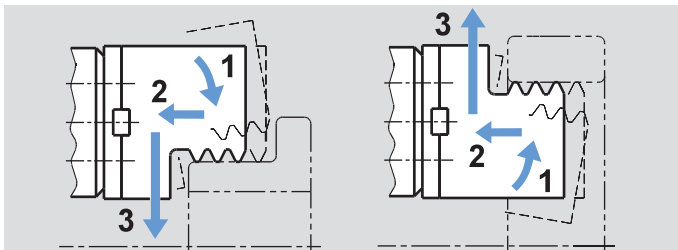

Principle of function:

- 1 pre-clamping - 2 active pull-down - 3 clamping
- For O.D. and I.D. clamping.

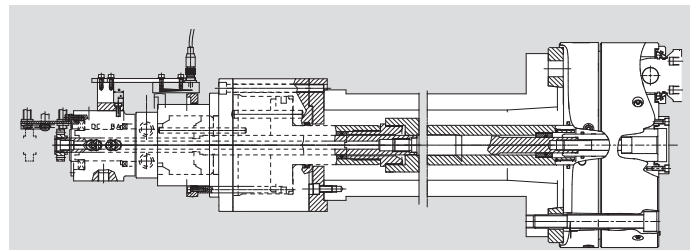

- **TSX-C:** chuck operated with a DCE cylinder with central bore for air sensing and / or coolant flush.

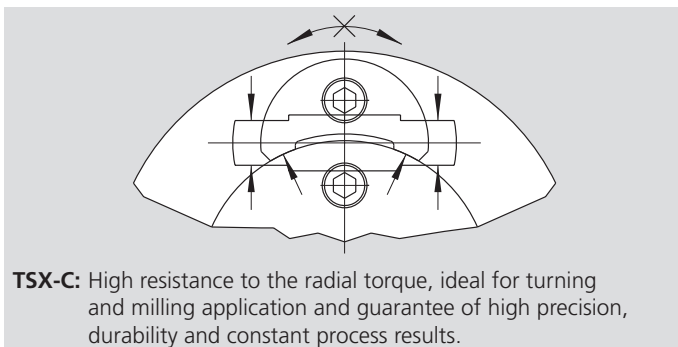

TSX-C: High resistance to the radial torque, ideal for turning and milling application and guarantee of high precision, durability and constant process results.

Technical data

SMW-AUTOBLOK Type		TSXR-C 265	TSXR-C 315
Number of jaws		2+2	2+2
Angular jaw stroke U° (TX)	deg.	3.3	3.9
Radial jaw stroke at distance h (TX)	mm	4	5.5
Axial piston stroke (TX)	mm	16	20
Max. draw pull** (TX)	kN	16	26
Max. gripping force at distance h** (TX)	kN	40	64
Angular jaw stroke U1° (TS)	deg.	4.2	4.6
Radial jaw stroke at distance h1 (TS)	mm	5.1	6.6
Axial piston stroke (TS)	mm	20	24
Max. draw pull** (TS)	kN	16	26
Max. gripping force at distance h1** (TS)	kN	40	64
Pull down movement (standard)	mm	0.1	0.1
Max. speed*	r.p.m.	3250	2500
Weight (plain back without top jaws)	kg	52	88
Moment of inertia	kg·m ²	0.45	1.1
Recommended actuating cylinders	Type	DCE 64-64	DCE 64-64
Id. No. TSXR-C (center mounting)		77992615	77993201

* The above maximum speed is allowed with standard weight / height top jaws and applying the full draw pull only. For more information please contact SMW-AUTOBLOK.

** For internal clamping reduce the draw pull by 30%.

High precision pull-down chuck Ø 265 - 315 mm

TSX-C 2+2

- Active pull-down
- 2+2 jaws
- Tongue & groove

Pull down chuck
4 jaws 2+2

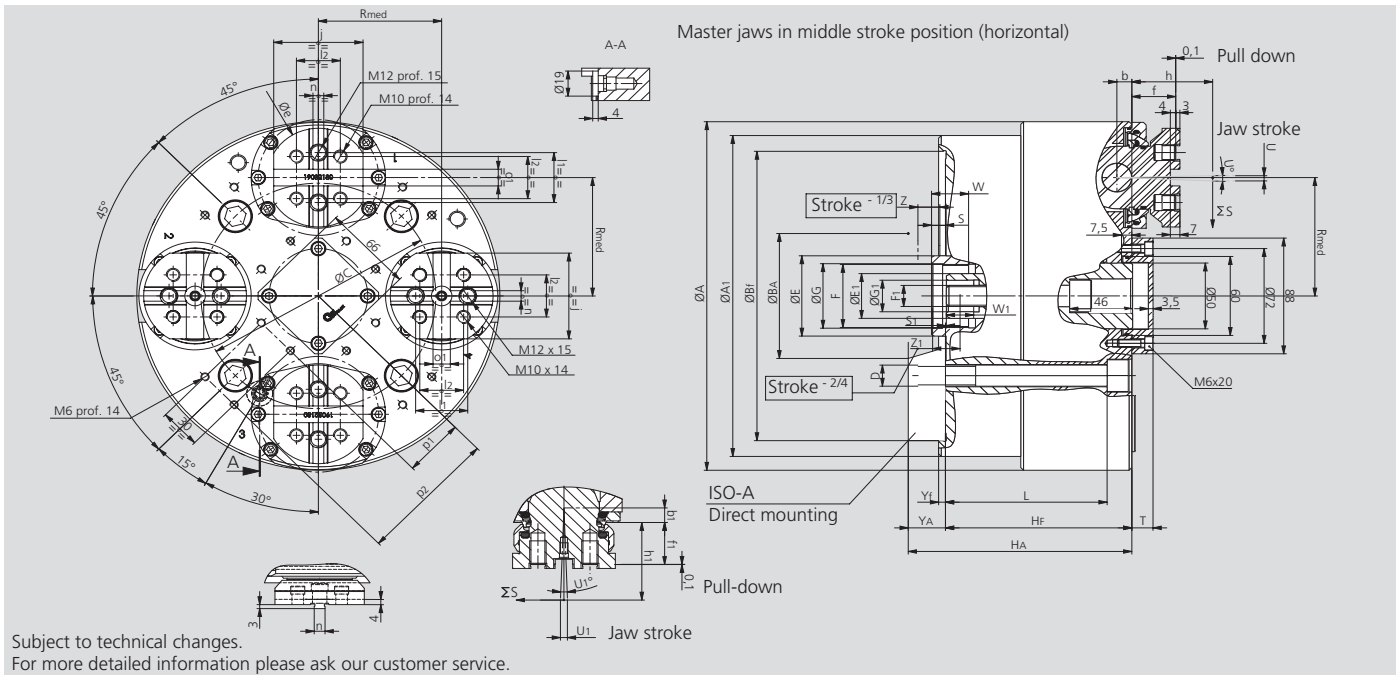

Subject to technical changes.
For more detailed information please ask our customer service.

SMW-AUTOBLOK Type			TSXR-C 265		TSXR-C 315	
Mounting			Z220	A8	Z300	A11
	A	mm		265		315
	Bf/BA H6	mm	220	139.719	300	196.869
	C	mm		171.4		235
	D	mm		M16		M20
	E	mm		48		48
	F	mm		M48 x 1.5		M88 x 1.5
	G H8	mm		49		49
	Hf/HA	mm	136	155	147	168
	E1	mm		34		34
	F1	mm		M16		M16
	G1 H8	mm		24		24
	A1	mm		244		315
	L	mm		118		124
	Rmed	mm		90		107
At middle stroke	S	mm		10.1		12.5
At middle stroke	S1	mm		0.6		1.4
	T	mm		15.5		15.5
Radial stroke	U°	deg.		3.3°		3.9°
Radial stroke	U1°	deg.		4.2°		4.6°
Radial stroke ⁽¹⁾ (1-3)	U	mm		4		5.5
Radial stroke ⁽¹⁾ (2-4)	U1	mm		5.1		6.6
	W	mm		27		27
	W1	mm		20		20
Axial piston stroke 1-3	Z	mm		16		20
Axial piston stroke 2-4	Z1	mm		20		24
	e	mm		75		80
	f	mm		32.1		32.1
	f1	mm		32		32
Reference height	h	mm		59		69
Reference height	h1	mm		59		69
	j	mm		65.2		72.2
	l1	mm		38		44.4
	l2	mm		32		36
	b	mm		10.9		12.9
	b1	mm		11		13.2
	n h8	mm		7.94		12.7
	o1 H7	mm		12.68		19.03
	Yf	mm		5		6
	p1	mm		44		44
	p2	mm		102		77
	p3	mm		-		102
	p4	mm		-		135

⁽¹⁾ Calculated at **h/h1** distance from the chuck's face (where normally the clamping takes place).